

Specification

Small Form Factor Pluggable

Duplex LC Receptacle – SFP28

25G/10G Dual-Rate

Optical Transceivers



Ordering Information

TAS-A1EB1-F17

Ordering Information:

Model Name	TAS-A1EB1-F17	Note
Voltage	3.3V	
Category	With DDMI	
Device type	1310 nm DFB	
Interface	AC / AC Coupling	
LOS	LVTTL	
Temperature	0°C ~ +70°C	
Distance	10km	
Latch Color	Blue 	

■ Features

- Compliant to IEEE802.3by 25GBASE-LR for TAS-A1EB1-F17
- Support 10Gb to 25.78Gb/s data links
- 25G 1310nm DFB transmitter
- 25G PIN photo-detector
- 2-wire interface for management specifications compliant with SFF-8472 digital diagnostic monitoring interface for optical transceivers
- Operating case temperature: 0 to 70°C
- All-metal housing for superior EMI performance
- 25G electrical interface (OIF CEI-28G-VSR)
- Maximum power consumption 1.5W
- Advanced firmware allows customer system encryption information to be stored in transceiver
- RoHS compliant

■ Applications

- High-speed storage area networks
- Computer cluster cross-connect
- Custom high-speed data pipes
- Inter Rack Connection

■ General Description

This 1310 nm DFB 25/10Gb/s SFP28 LR transceiver is designed to transmit and receive optical data over single mode optical fiber for link length up to 10km.

The module optical connection is duplex LC and shall be compatible with SFP28. The SFP28 LR module is a dual directional device with a transmitter and receiver plus a control management interface (2-wire interface) in the same physical package. 2-wire interface is used for serial ID, digital diagnostics and module control function.

Proposed Application Schematics

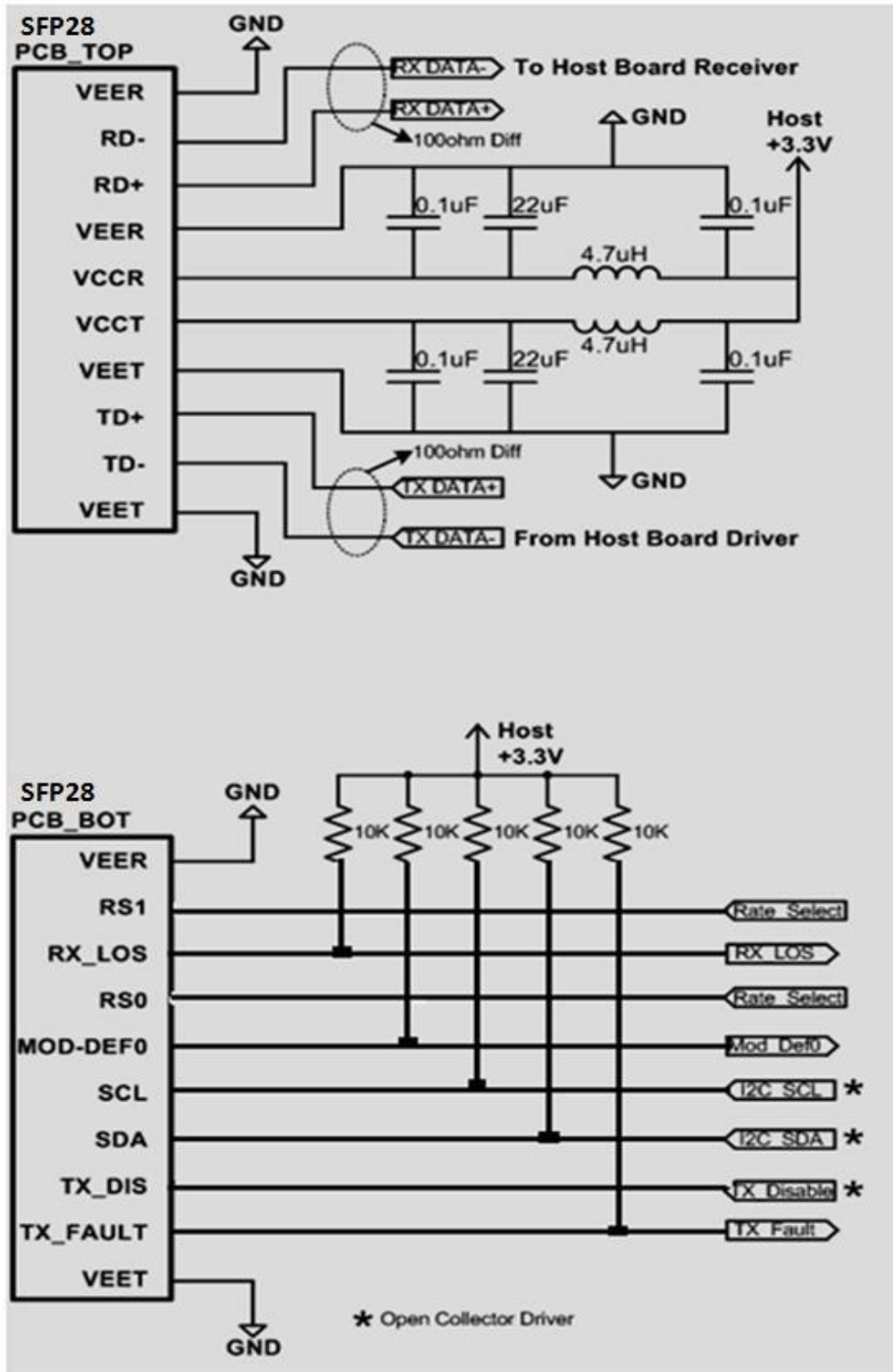

Transceiver Block Diagram

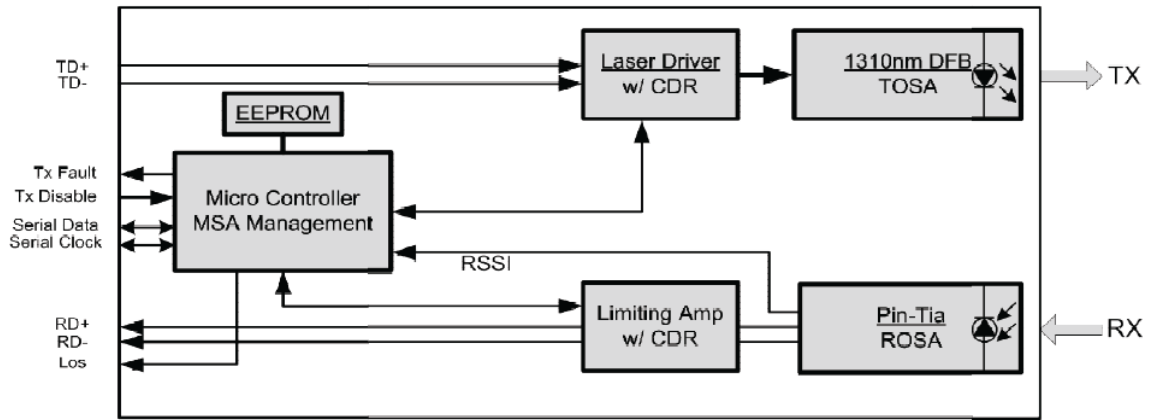

Pin Definition

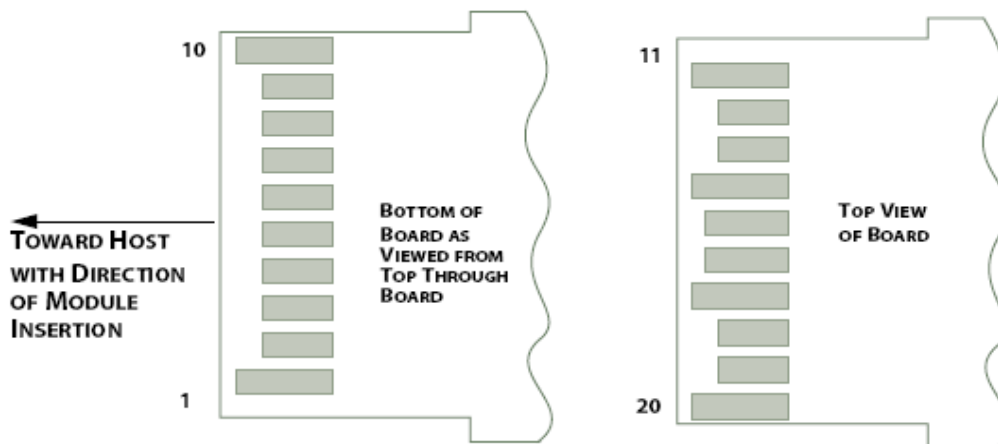
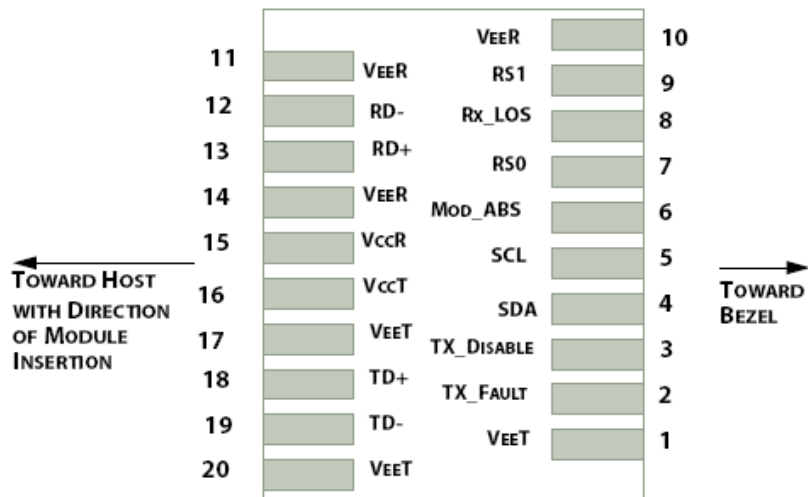

Pin Descriptions

PIN	Logic	Symbol	Name / Description	Note
1		VeeT	Module Transmitter Ground	1
2	LVTTL-O	TX_Fault	Module Transmitter Fault	
3	LVTTL-I	TX_Dis	Transmitter Disable; Turns off transmitter laser output	
4	LVTTL-I/O	SDA	2-Wire Serial Interface Data Line	2
5	LVTTL-I	SCL	2-Wire Serial Interface Clock	2
6		MOD_DEFO	Module Definition, Grounded in the module	
7	LVTTL-I	RS0	Rx Rate Select: Low = 10.3 Gbps Ethernet (Low Bandwidth) High = 25.78 Gbps (High Bandwidth)	
8	LVTTL-O	RX_LOS	Receiver Loss of Signal Indication Active LOW	
9	LVTTL-I	RS1	Tx Rate Select: Low = 10.3 Gbps Ethernet (Low Bandwidth) High = 25.78 Gbps (High Bandwidth)	
10		VeeR	Module Receiver Ground	1
11		VeeR	Module Receiver Ground	1
12	CML-O	RD-	Receiver Inverted Data Output	
13	CML-O	RD+	Receiver Data Output	
14		VeeR	Module Receiver Ground	1
15		VccR	Module Receiver 3.3 V Supply	
16		VccT	Module Transmitter 3.3 V Supply	
17		VeeT	Module Transmitter Ground	1
18	CML-I	TD+	Transmitter Non-Inverted Data Input	
19	CML-I	TD-	Transmitter Inverted Data Input	
20		VeeT	Module Transmitter Ground	1

Note:

1. Module ground pins GND are isolated from the module case.
2. Shall be pulled up with 4.7K-10Kohms to a voltage between 3.15V and 3.45V on the host board.

Absolute Maximum Ratings

Parameters	Symbol	Min.	Max.	Unit
Power Supply Voltage	VCC	0	3.6	V
Storage Temperature	Ts	-40	85	°C
ESD Tolerance on all pins			1	KV HBM
Operating Case Temperature	Top	0	70	°C
Relative Humidity	RH	5	85	%

Recommended Operating Environment

Recommended Operating Environment specifies parameters for which the electrical and optical characteristics hold unless otherwise noted.

Parameters	Symbol	Min.	Typical	Max	Unit
Power Supply Voltage	V _{CC}	3.135	3.3	3.465	V
Power Supply Current	I _{CC}		270	450	mA
Operating Case Temperature	Top	0	25	70	°C
Data Rate, each Lane		10.3125	25.78125		Gb/s

Optical Characteristics

The following optical characteristics are defined over the Recommended Operating Environment unless otherwise specified.

Parameter	Symbol	Min.	Typical	Max	Unit	Notes
Transmitter						
Center Wavelength	λ	1295	1310	1325	nm	
Side Mode Suppression Ratio	SMSR	30			dB	
Average Optical Power	P_{avg}	-7		2	dBm	
OMA 25.78Gbps 10.3Gbps	P_{OMA}	-4 -5		2.2	dBm	
Extinction Ratio	ER	3.5			dB	
Transmitter eye mask definition		(X1, X2, X3, Y1, Y2, Y3) = (0.31, 0.4, 0.45, 0.34, 0.38, 0.4)				1
Receiver						
Center Wavelength	λ	1260		1370	nm	
Unstressed Receiver Sensitivity (OMA) 25.78Gbps 10.3Gbps	Sens (OMA)			-11.3 -12.6	dBm	2, 3
LOS Assert	LOSA	-30			dBm	
LOS Deassert	LOSD			-15	dBm	
LOS Hysteresis	LOSH	0.5			dB	

Notes:

1. Hit ratio 5×10^{-5} per sample
2. 25.78Gbps at 5×10^{-5} BER, per IEEE802.3cc
3. For information only

Digital Diagnostic Functions

The following digital diagnostic characteristics are defined over the Recommended Operating Environment unless otherwise specified. It is compliant to SFF-8472 with internal calibration mode. For external calibration mode please contact our sales staff.

Parameter	Symbol	Min.	Max	Unit	Notes
Temperature monitor absolute error	DMI_Temp	-3	3	°C	
Laser power monitor absolute error	DMI_TX	-3	3	dB	
RX power monitor absolute error	DMI_RX	-3	3	dB	
Supply voltage monitor absolute error	DMI_VCC	-3%	3%	V	Full range
Bias current monitor	DMI_Ibias	-10%	10%	mA	

Electrical Characteristics

The following electrical characteristics are defined over the Recommended Operating Environment unless otherwise specified.

Parameter	Symbol	Min.	Typical	Max	Unit	Notes
Transmitter						
Differential Input	VIH - VIL	200		900	mVp-p	
Transmit Disable Voltage	V _D	2.0		V _{CC}	V	
Transmit Enable Voltage	V _{EN}	V _{EE}		V _{EE} +0.8	V	
SCL, SDA--High		2.5		V _{CC} +0.3	V	
SCL, SDA--Low		0		0.5	V	
Receiver						
Differential Input	VIH - VIL	500	800	1000	mVp-p	
LOS Fault	V _{LOS fault}	2.0		V _{CCHOST}	V	1
LOS Normal	V _{LOS norm}	V _{EE}		V _{EE} +0.8	V	1

Notes:

1. LOS is an open collector output. Should be pulled up with 4.7k – 10kohms on the host board. Normal operation is logic 0; loss of signal is logic 1. Maximum pull-up voltage is 5.5V.

Mechanical

Comply with SFF-8432 rev. 5.0, the improved Pluggable form factor specification.

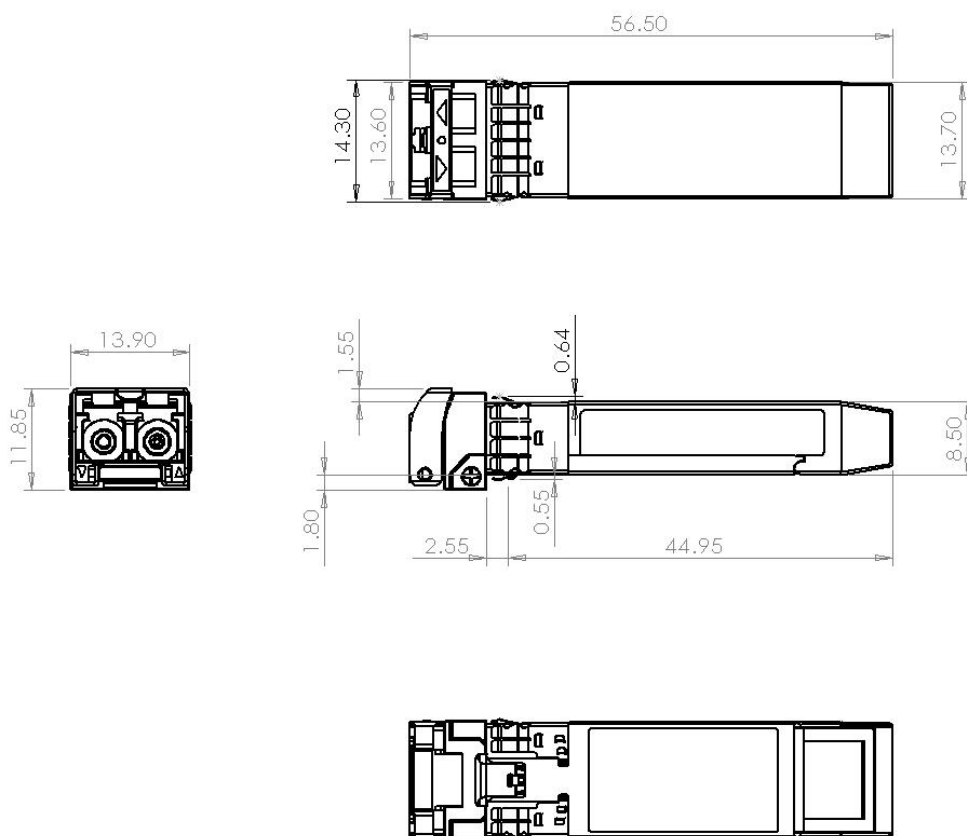

■ ESD

Normal ESD precautions are required during the handling of this module. This transceiver is shipped in ESD protective packaging. It should be removed from the packaging and handled only in an ESD protected environment.

■ LASER Safety

This is a Class 1 Laser Product according to IEC/EN60825-1:2014 (Third Edition). This product complies with 21 CFR 1040.10 and 1040.11 except for deviations pursuant to Laser Notice No. 56, MAY 8, 2019.

Caution:

Use of controls or adjustments or performance of procedures other than those specified herein may result in hazardous radiation exposure.

Attention: L'utilisation de commandes ou de réglages ou l'exécution de procédures autres que celles spécifiées dans le document peut entraîner une exposition à des radiations dangereuses.

■ Contact Information

Formerica OptoElectronics Inc. 5F-11, No.38, Taiyuan St., Zhubei City, Hsinchu County 30265, Taiwan Tel: +886-3-5600286 Fax: +886-3-5600239	San Diego, CA Tel: 1-949-466-8069
inquiry@formericaoe.com www.formericaoe.com	

■ Revision History

Date	Version	Description
09/07/2022	1.0	Initial release
10/11/2022	1.1	Correction of PN errors