

Specification

1.6T OSFP224 2xDR4

Optical Transceiver



TES-K19BF-CFC

■ Features

- OSFP MSA package of IHS
- IEEE 802.3dj_D2.0
- CMIS 4.0/5.0/5.2 compliance
- Sipro modulator-based transmitter
- Low power consumption 25W Max
- Two optical connectors: MPO-12/APC.
- Case temperature: 0 to 70C
- RoHS compliance

■ Applications

- 1600Gb/s SMF link up to 500M
- 1600Gb/s AI/ML & HPC Datacenter

■ General Descriptions

TES-K19BF-CFC is a 1600Gb/s 2xDR4 single mode optical transceiver for an Ethernet application. SMF optical line rate is 8x200Gb/s with PAM-4 modulation. OSFP form factor provides 8- channels of 200G-PAM4 via a DSP to enhance the signal integrity and assure an error-free transmission for AI/ML and HPC optical interconnects applications.

■ Absolute Maximum Ratings

The absolute maximum ratings are stress ratings only. Stresses greater than those listed below can cause permanent damage to the device. Functional operation of the modules at absolute maximum ratings is not implied. Exposure to absolute maximum rating conditions may affect device reliability.

Parameter	Symbol	Min.	Max.	Units
Storage Temperature Range	T _{STG}	-40	+85	°C
Supply Voltage	V _{CC}	-0.5	3.6	V
Relative Humidity	RH	15% to 85% non-condensing		

Recommended Operating Conditions

Parameter	Symbol	Min.	Max.	Unit
Case Temperature- Operating	T _{CASE}	0	70	°C
Supply Voltage	V _{CC}	3.135	3.465	V
Current	I _{CC}	-	7.58	A
Line Data Rate		-	106.25	GBd
Power Consumption	P _{DISS}		25	W
Link Distance over SMF		-	500	M

Transmitter Optical Specification

Transmitter Parameter	Min	Typical	Max	Unit	Conditions
Signaling rate, each lane (range)	106.25 ± 50 ppm			GBd	
Modulation Format	PAM4				
Lane Wavelength Range	1304.5	1311	1317.5	nm	
Operating link reach	0.5		500	m	
Average launch power, each lane	-3.3		4.0	dBm	
Optical Modulation Amplitude (OMA), each lane			4.2	dBm	
Outer OMA, each lane For Max (TDECQ, TECQ) < 0.9 dB	-0.3			dBm	
Outer OMA, each lane For 0.9 < Max (TDECQ, TECQ) < 3.4 dB	-1.2 + Max (TDECQ, TECQ)			dBm	
Transmitter dispersion and eye closure (TDECQ), each lane			3.4	dB	
Transmitter eye closure (TECQ), each lane			3.4	dB	
TDECQ – TECQ, each lane			2.5	dB	
TX Overshoot/Undershoot			22	%	
Average launch power of OFF transmitter each lane			-15	dBm	
Extinction ratio	3.5			dB	
RIN _{21.4OMA}			-139	dB/Hz	See Note 1
Optical return loss tolerance single lane, n = 1			15.5	dB	
Optical return loss tolerance multiple lanes, n > 1			21.4	dB	
Transmitter Reflectance			-26	dB	
NOTE: 1. 21.4 in RIN _{21.4OMA} referring to RIN characteristic under 21.4 dB optical return loss.					

Receiver Optical Specifications

Receive Parameter	Min	Typical	Max	Units	Conditions
Signaling rate, each lane(range)	106.25 ± 50 ppm			GBd	
Modulation format	PAM4				
Damage threshold, average received power, each lane	5			dBm	See Note 1
Average receive power, each lane	-6.3		4.0	dBm	See Note 2
Receive power, each lane (OMAouter)			4.2	dBm	
Receiver reflectance			-26	dB	
Receiver sensitivity (OMAouter) for TECQ ≤ 0.9dB, each lane			-3.4	dBm	
Receiver sensitivity (OMA outer) for 0.9 ≤ TECQ ≤ SECQ, each lane			-4.3 +TECQ	dBm	
Stressed receiver sensitivity (OMAouter), each lane			-0.9	dBm	See Note 3
Conditions of stressed receiver sensitivity test					
Stressed eye closure for PAM4 (SECQ), lane under test			3.4	dB	
OMAouter of each aggressor lane	4.2			dBm	
RX_LOS_Assert Min/Max	-18.0			dBm	
RX_LOS_De-Assert Min/Max			-8.9	dBm	
RX_LOS_Hysteresis	0.5		4	dB	
<p>NOTES:</p> <ol style="list-style-type: none"> The receiver shall be able to tolerate, without damage, continuous exposure to an optical input signal having this average power level. Average receive power, each lane (min) is informative and not the principal indicator of signal strength. A received power below this value cannot be compliant; however, a value above this does not ensure compliance. Measured with conformance test signal at TP3. See section 9.10. 					

Low Speed Electrical Specifications

Parameter	Symbol	Min	Max	Unit	Condition
SCL and SDA	VOL	0	0.4	V	IOL (max)=3.0mA for fast mode,20mA for Fast-mode plus
	VOH	Vcc-0.5	Vcc+0.3	V	
SCL and SDA	VIL	-0.3	Vcc*0.3	V	
	VIH	Vcc*0.7	Vcc +0.5	V	
Capacitance for SCL and SDA I/O pin	Ci		14	pF	
Total bus capacitive load for SCL and SDA	Cb		100	pF	3.0k Ohms Pull up resistor, max
			200	pF	1.6k Ohms Pull up resistor, max
V_INT/RSTn_1		0	1	V	for No Module
V_INT/RSTn_2		0	1	V	for Module installed, H_RSTn=Low
V_INT/RSTn_3		1.5	2.25	V	for Module installed, H_RSTn=High, M_INT=Low
V_INT/RSTn_4		2.75	3.465	V	for Module installed, H_RSTn=High,M_INT=High
V_LPWn/PRSn_1		0	1.1	V	for Module installed, H_LPWn=Low
V_LPWn/PRSn_2		1.4	2.25	V	for Module installed, H_LPWn=High
V_LPWn/PRSn_3		2.75	3.465	V	for No Module

High Speed Electrical Specification

➤ Transmitter electrical input characteristics

The Equation in the below table are referred to IEEE 802.3dj

Parameter	Min	Typical	Max	Unit	Notes
Signaling rate, per lane		106.25±50ppm		GBd	
Single-ended voltage tolerance (range)	-0.4		1.4	V	
DC common-mode voltage tolerance (range)	-0.05		1.05	V	
Peak-to-peak AC common-mode voltage tolerance (min)					
Low-frequency, VCMLF	0.032			V	
Full-band, VCMFB	0.08			dB	
Differential-mode to common-mode return loss, RLcd (min)	Equation(179-24)			dB	
Effective return loss, ERL (min)	8.5				
Amplitude tolerance		1		V	

➤ Receiver electrical output characteristics

The Equation in the below table are referred to IEEE 802.3dj

Parameter	Min	Typical	Max	Unit	Notes
Signaling rate per lane		106.25±50ppm		GBd	
Differential peak-to-peak voltage (max)					
Output disabled Output enabled			0.03 1	V	
DC common-mode voltage tolerance (range)	-0.05		1.05	V	
AC common-mode peak-to-peak voltage (max)					
Low-frequency, VCMLF Full-band, VCMFB			0.015 0.06	V	
Effective return loss, ERL (min)	8.5			dB	
Common-mode to common-mode return loss, RLcc (min)	Equation (179-16)			dB	
Common-mode to differential-mode return loss, RLdc (min)	Equation (179-17)			dB	
Transmitter steady-state voltage, vf(range)	0.4		0.5	V	
Linear fit pulse peak ratio, Rpeak (min)	TBD				
Level separation mismatch ratio RLM (min)	0.95				
Transmitter output waveform					
Absolute value of step size for all taps (min)		0.005			
Absolute value of step size for all taps (max)		0.025			
Value at minimum state for c (-3) (max)		-0.06			
Value at maximum state for c (-2) (min)		0.12			
Value at minimum state for c (-1) (max)		-0.34			
Value at minimum state for c (0) (max)		0.5			
Value at minimum state for c (1) (max)		-0.2			
Difference signal-to-noise-and-distortion ratio, dSNDR (min)	0			dB	
Signal-to-residual-inter symbol-interference ratio, SNRISI (min)	28			dB	
Output jitter (max)					
JRMS EOJ03			0.023 0.025	UI	
J4u03			- 0.118		

Module Block Diagram

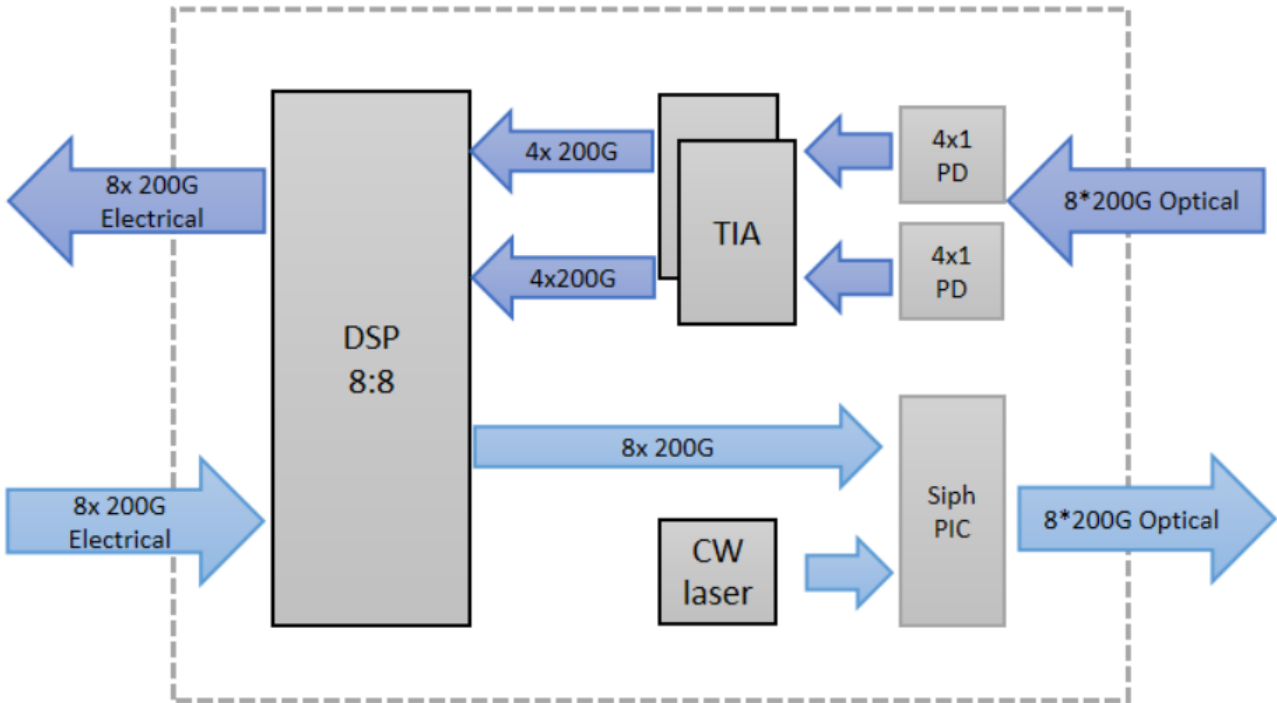

Module Electrical Connector

The module is in full compliance to OSFP MSA (Rev 1.1)

The color code indicates the power-on sequence when plugging the module into an OSFP cage when the socket is hot. The green traces are GND pins; Orange traces are VCC and other colors are low-speed control and high-speed signal pins.

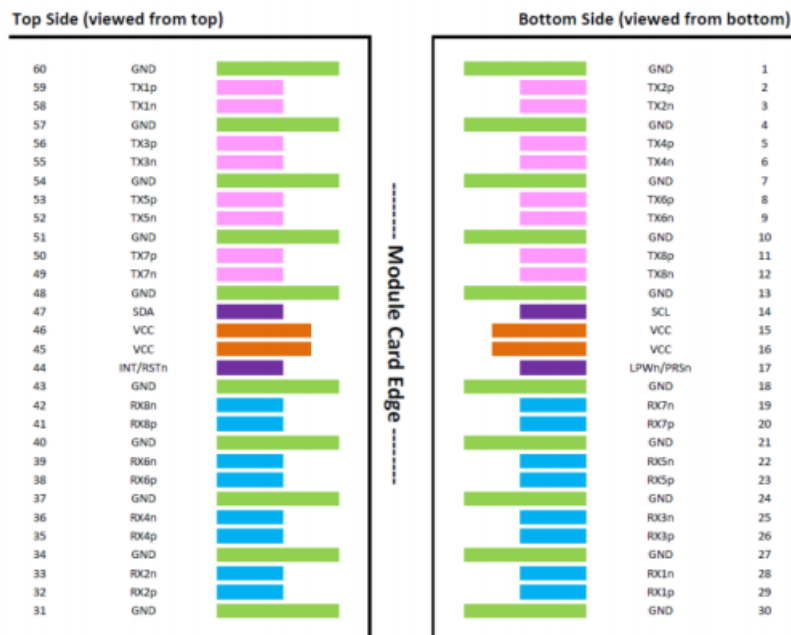

Connector Pin Descriptions

Pin#	Symbol	Description	Logic	Direction	Plug Sequence	Notes
1	GND	Ground			1	
2	TX2p	Transmitter Data Non-Inverted	CML-I	Input from Host	3	
3	TX2n	Transmitter Data Inverted	CML-I	Input from Host	3	
4	GND	Ground			1	
5	TX4p	Transmitter Data Non-Inverted	CML-I	Input from Host	3	
6	TX4n	Transmitter Data Inverted	CML-I	Input from Host	3	
7	GND	Ground			1	
8	TX6p	Transmitter Data Non-Inverted	CML-I	Input from Host	3	
9	TX6n	Transmitter Data Inverted	CML-I	Input from Host	3	
10	GND	Ground			1	
11	TX8p	Transmitter Data Non-Inverted	CML-I	Input from Host	3	
12	TX8n	Transmitter Data Inverted	CML-I	Input from Host	3	
13	GND	Ground			1	
14	SCL	2-wire Serial interface clock	LVC MOSI/O	Bi-directional	3	1
15	VCC	+3.3v Power		Power from Host	2	
16	VCC	+3.3v Power		Power from Host	2	
17	LPWN/PRSn	Lower-Power Mode/Module Present	Multi-Level	Bi-directional	3	2
18	GND	Ground			1	
19	RX7n	Receiver Data inverted	CML-O	Output to Host	3	
20	Rx7p	Receiver Data Non-Inverted	CML-O	Output to Host	1	
21	GND	Ground			1	
22	RX5n	Receiver Data inverted	CML-O	Output to Host	3	
23	RX5p	Receiver Data Non-Inverted	CML-O	Output to Host	3	
24	GND	Ground			1	
25	RX3n	Receiver Data inverted	CML-O	Output to Host	3	
26	RX3p	Receiver Data Non-Inverted	CML-O	Output to Host	3	
27	GND	Ground			1	
28	RX1n	Receiver Data inverted	CML-O	Output to Host	3	
29	RX1p	Receiver Data Non-Inverted	CML-O	Output to Host	3	

30	GND	Ground			1	
31	GND	Ground			1	
32	Rx2p	Receiver Data Non-Inverted	CML-O	Output to Host	3	
33	RX2n	Receiver Data inverted	CML-O	Output to Host	3	
34	GND	Ground			1	
35	RX4p	Receiver Data Non-Inverted	CML-O	Output to Host	3	
36	RX4n	Receiver Data inverted	CML-O	Output to Host	3	
37	GND	Ground			1	
38	RX6p	Receiver Data Non-Inverted	CML-O	Output to Host	3	
39	RX6n	Receiver Data inverted	CML-O	Output to Host	3	
40	GND	Ground			1	
41	RX8p	Receiver Data Non-Inverted	CML-O	Output to Host	3	
42	RX8n	Receiver Data Inverted	CML-O	Output to Host	3	
43	GND	Ground			1	
44	INT/RSTn	Module Interrupt/Module Reset	Multi-Level	Bi-directional	3	2
45	VCC	+3.3V Power		Power from Host	2	
46	VCC	+3.3V Power		Power from Host	2	
47	SDA	2-wire Serial interface data	LVC MOSI/O	Bi-directional	3	1
48	GND	Ground			1	
49	TX7n	Transmitter Data Inverted	CML-I	Input from Host	3	
50	TX7p	Transmitter Data Non-Inverted	CML-I	Input from Host	3	
51	GND	Ground			1	
52	TX5n	Transmitter Data Inverted	CML-I	Input from Host	3	
53	TX5p	Transmitter Data Non-Inverted	CML-I	Input from Host	3	
54	GND	Ground			1	
55	TX3n	Transmitter Data Inverted	CML-I	Input from Host	3	
56	TX3p	Transmitter Data Non-Inverted	CML-I	Input from Host	3	
57	GND	Ground			1	
58	TX1n	Transmitter Data Inverted	CML-I	Input from Host	3	
59	TX1p	Transmitter Data Non-Inverted	CML-I	Input from Host	3	
60	GND	Ground			1	

Notes

- 1: Open-Drain with pull-up resistor on Host
- 2: See pin description for required circuit

Mechanical Specifications

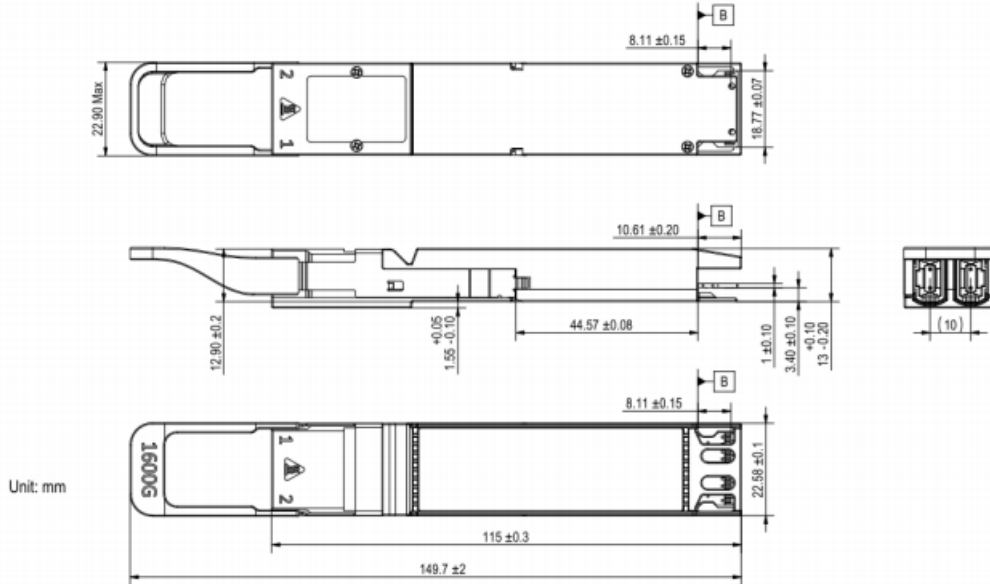
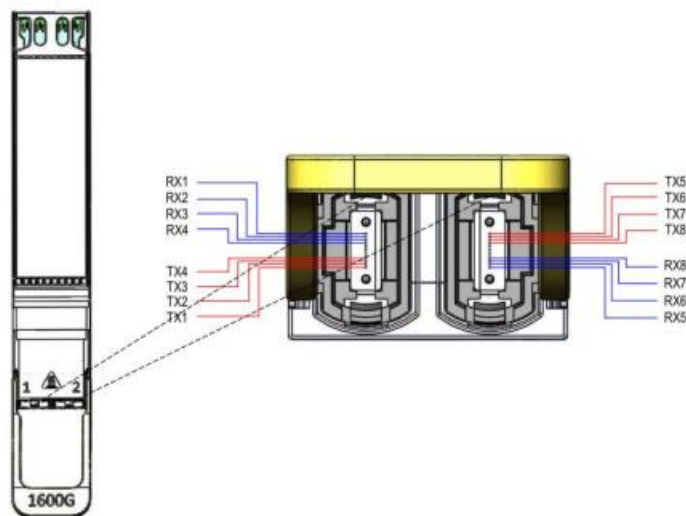

Figure 2. Package Outline Drawing

Dual Optical Connectors



■ Ordering information

Part No.	Description	Temperature
TES-K19BF-CFC	1.6T OSFP224 2xDR4 Optical Transceiver	0° C to +70° C

■ **Contact Information**

Formerica OptoElectronics Inc.

5F-11, No.38, Taiyuan St., Zhubei City,

Hsinchu County 30265, Taiwan

Tel: +886-3-5600286

Fax: +886-3-5600239

inquiry@formericaoe.com

www.formericaoe.com

■ Revision History

Date	Version	Description
02/05/2026	1.0	Initial release