

## Specification

### QSFP28 to 4xSFP28 AOC Product



## Ordering Information

**TQS-214H8-XCQxx**

Distance

Part Number	Description
TQS-214H8-XCQ01	QSFP28 to SFP28 Breakout Active Optical Cable 1m
TQS-214H8-XCQ03	QSFP28 to SFP28 Breakout Active Optical Cable 3m
TQS-214H8-XCQ05	QSFP28 to SFP28 Breakout Active Optical Cable 5m
TQS-214H8-XCQ07	QSFP28 to SFP28 Breakout Active Optical Cable 7m
TQS-214H8-XCQ10	QSFP28 to SFP28 Breakout Active Optical Cable 10m
TQS-214H8-XCQ20	QSFP28 to SFP28 Breakout Active Optical Cable 20m

Model Name	Voltage	Category	Device type	Interface	Temperature
TQS-214H8-XCQxx	3.3V	With DDMI	VCSEL/PIN	CML/CML LVTTTL	0°C~+70°C

## Features

- Full-Duplex & 25-Gbps per lane with maximum aggregate speed of 100-Gbps.
- 3.3V single power supply
- Selectable CDR Retiming
- QSFP28 and SFP28 MSA compliant
- Low power consumption of max. 2.5W at QSFP28 and max. 1.0W at SFP28 side
- Hot pluggable interface
- Compliant to SFF-8665 (QSFP28) Revision 1.8, and SFF-8402 (SFP28)
- Programmable EEPROM for serial identification through I<sup>2</sup>C interface
- RoHS compliant

## Applications

- Ethernet for 100GBASE-SR4
- InfiniBand EDR

## Absolute Maximum Ratings

Parameter	Symbol	Min	Max	Unit	Note
Storage temperature	T <sub>S</sub>	-40	85	°C	1
3.3V Power Supply voltage	V <sub>CC</sub>	-0.5	3.6	V	
Relative humidity	RH	0	85	%	2

## Recommended Operating Conditions

Parameter	Symbol	Min	Typ	Max	Unit	Note
Case Operating Temperature	T <sub>OP</sub>	0		70	°C	
Power Supply voltage	V <sub>CC</sub>	3.14	3.3	3.47	V	
Data Rate per Channel	DR			25.78125	Gbps	
Control Input Voltage High	V <sub>IN-H</sub>	2		V <sub>CC</sub>	V	
Control Input Voltage Low	V <sub>IN-L</sub>	0		0.8		

**Electrical Characteristics (QSFP28)**

Parameter	Symbol	Min	Typ.	Max	Unit	Note
<b>Transceiver Electrical Characteristics</b>						
TRx Power Consumption				2.5	W	
Supply Current				757	mA	
<b>Transmitter</b>						
Overload Differential Voltage pk-pk	TP1a	900			mV	
Common Mode Voltage (Vcm)	TP1	-350		2850	mV	1
Differential Termination Resistance Mismatch	TP1			10	%	At 1MHz
Differential Return Loss (SDD11)	TP1			See CEI-28G-VSR Equation 13-19	dB	
Common Mode to Differential conversion and Differential to Common Mode conversion (SDC11, SCD11)	TP1			See CEI-28G-VSR Equation 13-20	dB	
Stressed Input Test	TP1a	See CEI-28G-VSR Section 13.3.11.2.1				
<b>Receiver</b>						
Differential Voltage, pk-pk	TP4			900	mV	
Common Mode Voltage (Vcm)	TP4	-350		2850	mV	1
Common Mode Noise, RMS	TP4			17.5	mV	
Differential Termination Resistance Mismatch	TP4			10	%	At 1MHz
Differential Return Loss (SDD22)	TP4			See CEI-28G-VSR Equation 13-19	dB	
Common Mode to Differential conversion and Differential to Common Mode conversion	TP4			See CEI-28G-VSR Equation	dB	

(SDC22, SCD22)				13-21		
Common Mode Return Loss (SCC22)	TP4			-2	dB	2
Transition Time, 20 to 80%	TP4	9.5			Ps	
Eye Width at $10^{-15}$ probability	TP4	0.57			UI	
Eye Height at $10^{-15}$ probability	TP4	228			mV	

**Notes:**

1.  $V_{cm}$  is generated by the host. Specification includes effects of ground offset voltage.
2. From 250MHz to 30GHz.

### Electrical Characteristics (SFP28)

Parameter	Symbol	Min	Typ.	Max	Unit	Note
<b>Transceiver Electrical Characteristics</b>						
TRx Power Consumption				1.0	W	1
Supply Current				300	mA	1
<b>Transmitter</b>						
Overload Differential Voltage pk-pk	TP1a	900			mV	
Common Mode Voltage ( $V_{cm}$ )	TP1	-350		2850	mV	2
Differential Termination Resistance Mismatch	TP1			10	%	At 1MHz
Differential Return Loss (SDD11)	TP1			See CEI-28G-VSR Equation 13-19	dB	
Common Mode to Differential conversion and Differential to Common Mode conversion (SDC11, SCD11)	TP1			See CEI-28G-VSR Equation 13-20	dB	
Stressed Input Test	TP1a	See CEI-28G-VSR Section 13.3.11.2.1				
<b>Receiver</b>						
Differential Voltage, pk-pk	TP4			900	mV	
Common Mode Voltage ( $V_{cm}$ )	TP4	-350		2850	mV	2
Common Mode Noise, RMS	TP4			17.5	mV	

Differential Termination Resistance Mismatch	TP4			10	%	At 1MHz
Differential Return Loss (SDD22)	TP4			See CEI-28G-VSR Equation 13-19	dB	
Common Mode to Differential conversion and Differential to Common Mode conversion (SDC22, SCD22)	TP4			See CEI-28G-VSR Equation 13-21	dB	
Common Mode Return Loss (SCC22)	TP4			-2	dB	3
Transition Time, 20 to 80%	TP4	9.5			Ps	
Eye Width at $10^{-15}$ probability (EW15)	TP4	0.57			UI	
Eye Height at $10^{-15}$ probability (EH15)	TP4	228			mV	

**Notes:**

1. Per terminal.
2. Vcm is generated by the host. Specification includes effects of ground offset voltage.
3. From 250MHz to 30GHz.

QSFP28 Module Pad Assignments and Descriptions

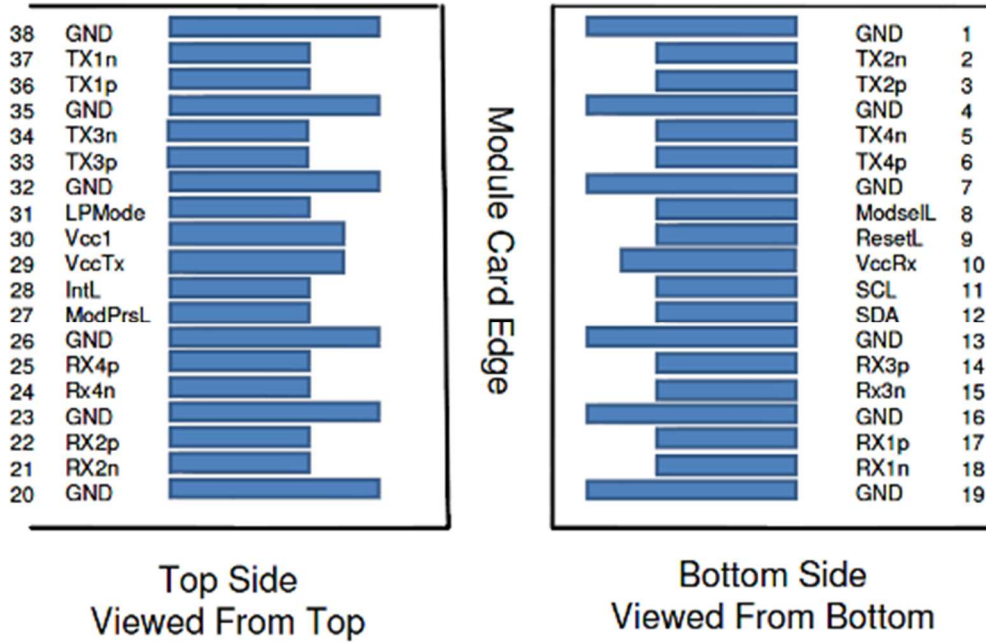

Pin	Logic	Symbol	Description	Plug Sequence	Notes
1		GND	Ground	1	1
2	CML-I	Tx2n	Transmitter Inverted Data Input	3	
3	CML-I	Tx2p	Transmitter Non-Inverted Data Input	3	
4		GND	Ground	1	1
5	CML-I	Tx4n	Transmitter Inverted Data Input	3	
6	CML-I	Tx4p	Transmitter Non-Inverted Data Input	3	
7		GND	Ground	1	1
8	LVTTL-I	ModSelL	Module Select	3	
9	LVTTL-I	ResetL	Module Reset	3	
10		Vcc Rx	+3.3V Power Supply Receiver	2	2
11	LVC MOS-I/O	SCL	2-wire serial interface clock	3	
12	LVC MOS-I/O	SDA	2-wire serial interface data	3	
13		GND	Ground	1	2
14	CML-O	Rx3p	Receiver Non-Inverted Data Output	3	
15	CML-O	Rx3n	Receiver Inverted Data Output	3	
16		GND	Ground	1	1
17	CML-O	Rx1p	Receiver Non-Inverted Data Output	3	
18	CML-O	Rx1n	Receiver Inverted Data Output	3	
19		GND	Ground	1	1
20		GND	Ground	1	1
21	CML-O	Rx2n	Receiver Inverted Data Output	3	
22	CML-O	Rx2p	Receiver Non-Inverted Data Output	3	
23		GND	Ground	1	1
24	CML-O	Rx4n	Receiver Inverted Data Output	3	
25	CML-O	Rx4p	Receiver Non-Inverted Data Output	3	
26		GND	Ground	1	1
27	LVTTL-O	ModPrsL	Module Present	3	
28	LVTTL-O	IntL	Interrupt	3	
29		Vcc Tx	+3.3V Power supply transmitter	2	2
30		Vcc1	+3.3V Power supply	2	2
31	LVTTL-I	LPMode	Low Power Mode	3	
32		GND	Ground	1	1
33	CML-I	Tx3p	Transmitter Non-Inverted Data Input	3	
34	CML-I	Tx3n	Transmitter Inverted Data Input	3	
35		GND	Ground	1	1
36	CML-I	Tx1p	Transmitter Non-Inverted Data Input	3	

---

37	CML-I	Tx1n	Transmitter Inverted Data Input	3	
38		GND	Ground	1	1

**Note:**

1. **GND** is the symbol for signal and supply (power) common for the QSFP28 module. All are common within the QSFP28 module and all module voltages are referenced to this potential unless otherwise noted. Connect these directly to the host board signal-common ground plane.
2. **Vcc Rx, Vcc1** and **Vcc Tx** are the receiver and transmitter power supplies and shall be applied concurrently. Requirements defined for the host side of the Host Edge Card Connector are listed in Table. Recommended host board power supply filtering is shown in next page. **Vcc Rx Vcc1** and **Vcc Tx** may be internally connected within the QSFP28 module in any combination. The connector pins are each rated for a maximum current of 500 mA.



**SFP28 Module Pad Assignments and Descriptions**

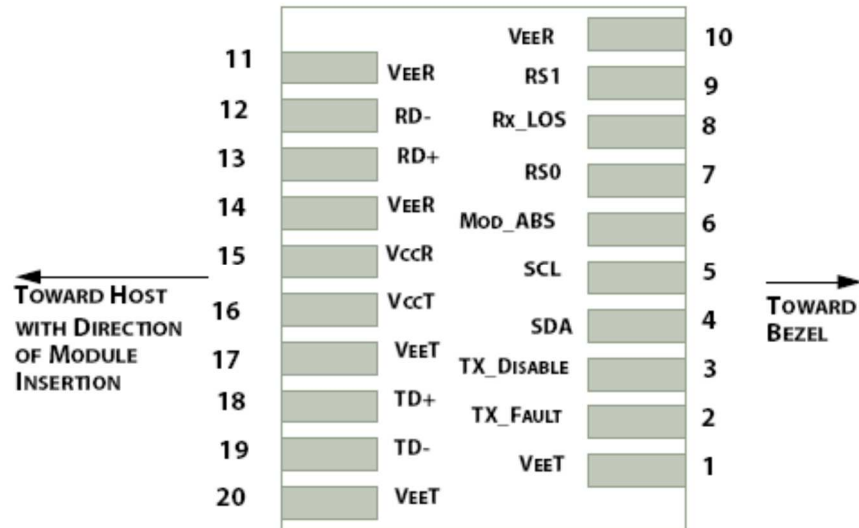

Pin	Logic	Symbol	Description	Plug Sequence	Notes
1	VeeT		Module Transmitter Ground		1
2	Tx_Fault	LVTTL-O	Not supported.		3
3	Tx_Disable	LVTTL-I	Not supported.		3
4	SDA	LVTTL-I/O	2-wire Serial Interface Data Line		2
5	SCL	LVTTL-I/O	2-wire Serial Interface Clock		2
6	Mod_ABS		Module Absent		2
7	RS0	LVTTL-I	Not supported.		3
8	Rx_LOS	LVTTL-O	Not supported.		2
9	RS1	LVTTL-I	Not supported.		3
10	VeeR		Module Receiver Ground		1
11	VeeR		Module Receiver Ground		1
12	RD-	CML-O	Receiver Inverted Data Output		
13	RD+	CML-O	Receiver Non-Inverted Data Output		
14	VeeR		Module Receiver Ground		1
15	VccR		Module Receiver 3.3 V Supply		4
16	VccT		Module Transmitter 3.3 V Supply		4
17	VeeT		Module Transmitter Ground		1
18	TD+	CML-I	Transmitter Non-Inverted Data Input		
19	TD-	CML-I	Transmitter Inverted Data Input		
20	VeeT		Module Transmitter Ground		1

**Note:**

1. Module circuit ground pins are isolated from the module chassis ground.
2. Pullup to VccHost with 4.7k – 10k  $\Omega$ .
3. No connection required.
4. Power supply filtering circuit required.

## Memory Map

The memory map is structured as a single address and multiple page approaches, according to the QSFP28 SFF-8636 MSA specification as shown in the below. For more detailed description of this memory map or lower pages, please see our Memory Map document with flexible customization settings.

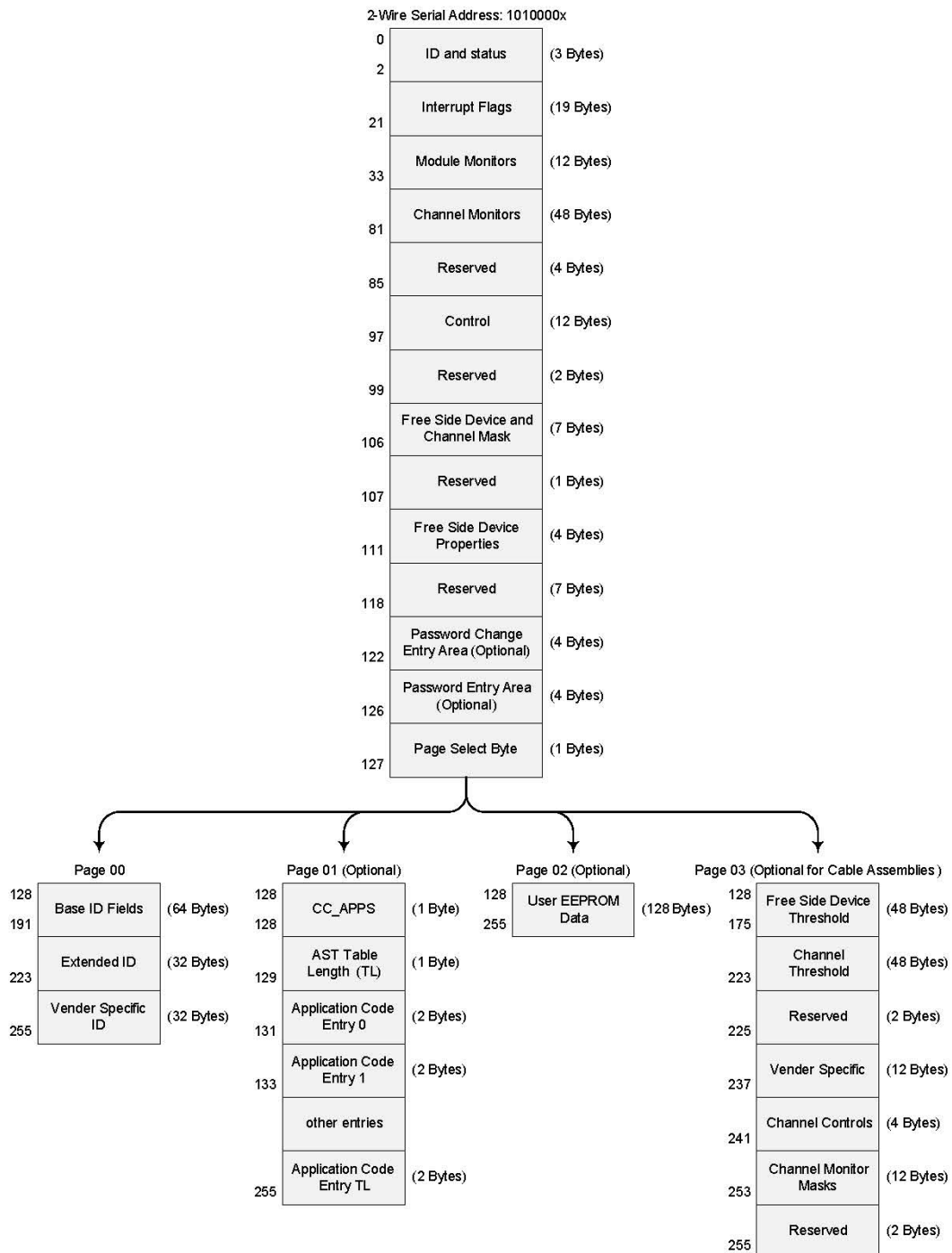

### Module Outline

(Unit: mm)

#### QSFP28

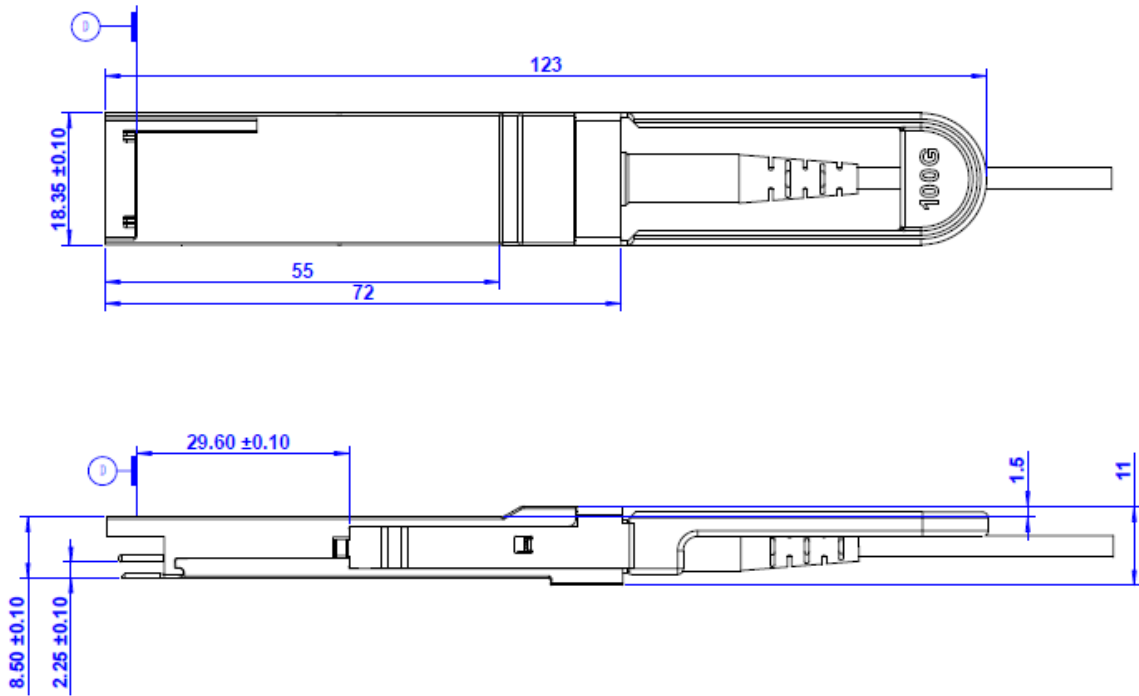

#### SFP28

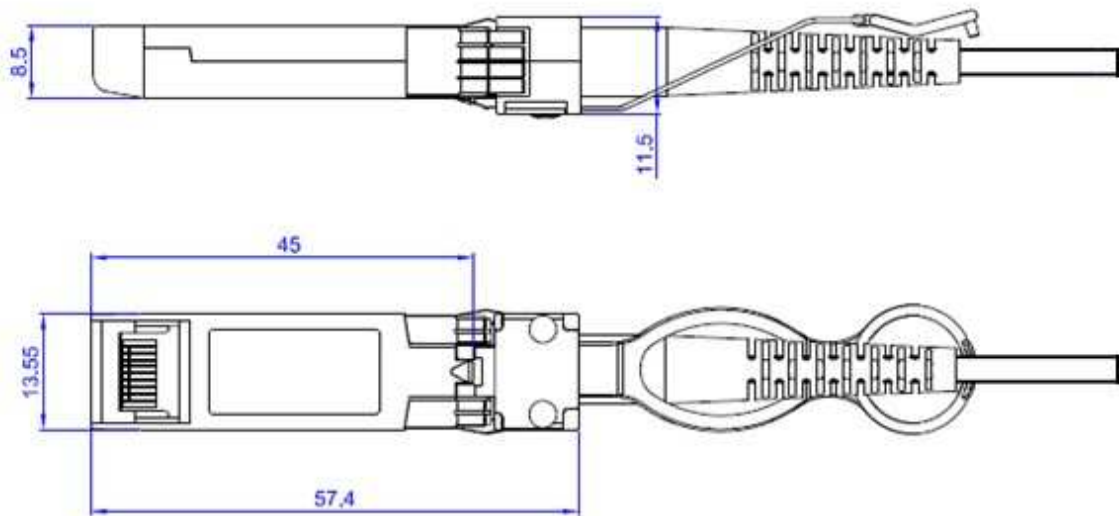

## Laser Safety

This is a laser class 1M product according to IEC/EN 60825-1:2014 (Third Edition). This product complies with 21 CFR 1040.10 and 1040.11 except for deviations pursuant to Laser Notice No. 50, dated (June 24, 2007).

## Caution

Laser Radiation. Do not expose users to telescopic optics.

## ESD

Normal ESD precautions are required during the handling of this module. This transceiver is shipped in ESD protective packaging. It should be removed from the packaging and handled only in an ESD protected environment.

## Contact Information

### Formerica OptoElectronics Inc.

5F-11, No.38, Taiyuan St., Zhubei City,

Hsinchu County 30265, Taiwan

Tel: +886-3-5600286

Fax: +886-3-5600239

### San Diego, CA

Tel: 1-949-466-8069

[inquiry@formericaoe.com](mailto:inquiry@formericaoe.com)

[www.formericaoe.com](http://www.formericaoe.com)

---

## Revision History

Date	Version	Description
06/14/2017	1.0	Initial release
03/01/2018	1.1	Modify the description of <b>Laser Safety</b> . Add <b>Caution</b> .
03/22/2019	1.2	1. Footer style change. 2. Contact information has been added on the last page.