

## Specification

### Quad Small Form-factor Pluggable Plus 40G QSFP+ Active Optical Cable ( OM3 Orange )



**TQS-Q1L58-X85xx**

Length

Model Name	TQS-Q1L58-X8501	TQS-Q1L58-X8503	TQS-Q1L58-X8505	TQS-Q1L58-X8507	TQS-Q1L58-X8510	TQS-Q1L58-X8520	Note
Voltage	3.3V						
Device type	VCSEL/PIN						
Interface	CML/CML						
LOS	LVTTL						
Temperature	0°C ~ +70°C						
Length	1M	3M	5M	7M	10M	20M	
Latch color	Black ( 426C ) <span style="background-color: black; color: black;">XXXXXX</span>						

## ■ Description

Formerica OptoElectronics Inc. Quad Small Form-factor Pluggable (QSFP) product is a new high speed pluggable I/O interface products. This interconnecting system offers 4 channels and maximum bandwidth of 40Gbps which are based on the proprietary technique Chip On Board (COB). This module provides high performance and excellent efficiency in the optical communication.

## ■ Features

- Compliant with 40G Ethernet IEEE 802.3ae 40GBASE-SR4 standards
- QSFP footprint (Quad small form-factor, pluggable)
- Supports 40 Gbps data rate links of up to 100 m
- Compliant with QDR/DDR Infiniband data rates
- Hot pluggable electrical interface
- RoHS Compliant

## ■ Applications

- 40GBASE-SR4 Ethernet links
- Infiniband QDR and DDR interconnects
- Client-side 40G Telecom connections

## Absolute Maximum Rating

Not necessarily applied together. Exceeding these values may cause permanent damage. Functional operation under these conditions is not implied.

Parameter	Symbol	Min	Typical	Max	Unit	Note
Storage Temperature	Ts	0		70	°C	1
Relative Humidity	RH	5		85	%	2
Data Input Voltage- Single Ended		-0.5		Vcc+0.5		
Center Wavelength	$\lambda$	840		860	nm	

### Notes:

- Limited by the fiber cable jacket, not the active ends.
- Non-condensing.

## Recommended Operation Conditions

Parameter	Symbol	Min	Typical	Max	Unit	Note
Case Temperature	Top	0	40	70	°C	
3.3 V Power Supply Voltage	Vcc	3.135	3.3	3.465	V	
Signal Rate per Channel		2.5		10.3125	GB/s	1
Control Input Voltage High	Vih	2		Vcc+0.3	V	
Control Input Voltage Low	Vil	-0.3		0.8	V	
Two Wire Serial (TWS) Interface Clock Rate			100		kHz	
Power Supply Noise				50	mV	2
Receiver Differential Data Output Load			100		Ohms	
Standard Cable Lengths		3		100	m	
Bit Error Ratio			10 <sup>-12</sup>			3

### Notes:

- Lane speed up to 12.5-Gbps is available upon customer requests.
- Power supply noise is defined as peak-to-peak noise amplitude over 1K to 15 MHz frequency range at host supply side by the recommended power supply filter for module. See Section 10 for the recommended power supply filter.
- Bit-Error-Rate (BER) is tested with PRBS 2<sup>31</sup>-1 pattern.

## Electrical Characteristics

Parameter	Symbol	Min	Typical	Max	Unit	Note
<b>Transceiver</b>						
Power Consumption				1.5	W	
Supply Current				420	mA	
Initialization Time	tpwr init			2000	ms	1
<b>Receiver</b>						
Data Output Differential Peak-to-Peak Voltage Swing	$\Delta V_{DO}$ pp	200		900	mVpp	
Output Total Jitter				62	ps	
BER				$10^{-12}$		PRBS3 1

### Notes:

1. "Initialization Time" is the time from when the supply voltages reach and remain above the minimum "Recommended Operating Conditions" to the time when the module enables TWS access. The module at that point is fully functional.

## Recommended Host Board POWER Supply Circuit

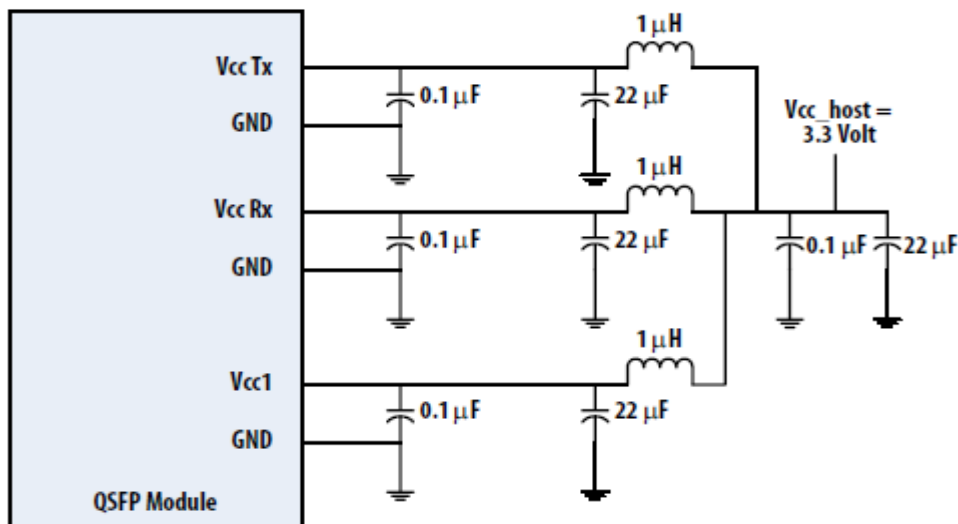

■ QSFP+ Module Pad Assignments and Descriptions

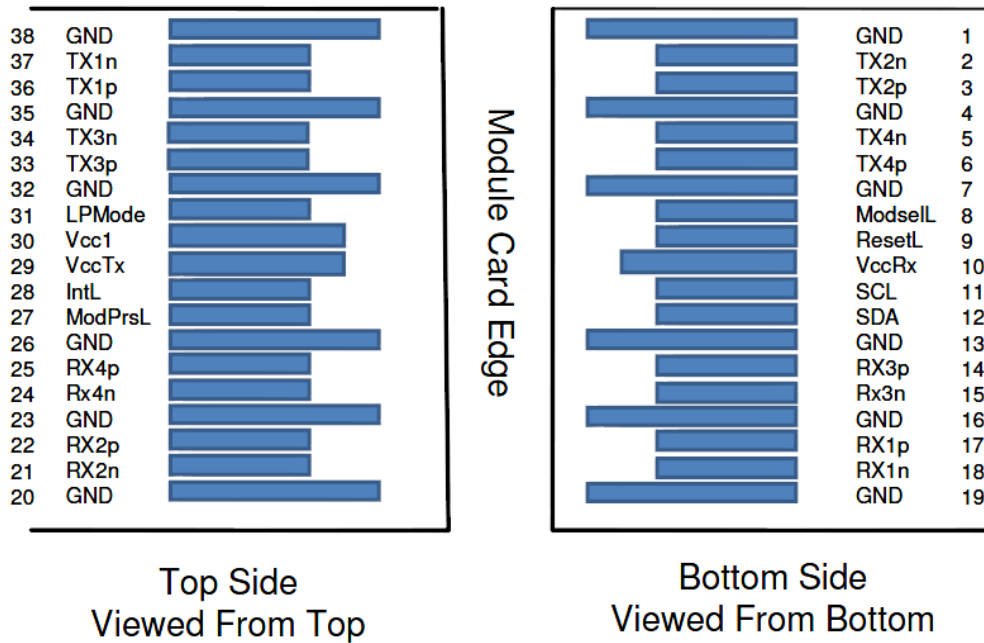

Pin	Logic	Symbol	Description	Plug Sequence	Notes
1		GND	Ground	1	1
2	CML-I	Tx2n	Transmitter Inverted Data Input	3	
3	CML-I	Tx2p	Transmitter Non-Inverted Data Input	3	
4		GND	Ground	1	1
5	CML-I	Tx4n	Transmitter Inverted Data Input	3	
6	CML-I	Tx4p	Transmitter Non-Inverted Data Input	3	
7		GND	Ground	1	1
8	LVTTL-I	ModSelL	Module Select	3	
9	LVTTL-I	ResetL	Module Reset	3	
10		Vcc Rx	+3.3V Power Supply Receiver	2	2
11	LVC MOS-I/O	SCL	2-wire serial interface clock	3	
12	LVC MOS-I/O	SDA	2-wire serial interface data	3	
13		GND	Ground	1	2
14	CML-O	Rx3p	Receiver Non-Inverted Data Output	3	
15	CML-O	Rx3n	Receiver Inverted Data Output	3	

16		GND	Ground	1	1
17	CML-O	Rx1p	Receiver Non-Inverted Data Output	3	
18	CML-O	Rx1n	Receiver Inverted Data Output	3	
19		GND	Ground	1	1
20		GND	Ground	1	1
21	CML-O	Rx2n	Receiver Inverted Data Output	3	
22	CML-O	Rx2p	Receiver Non-Inverted Data Output	3	
23		GND	Ground	1	1
24	CML-O	Rx4n	Receiver Inverted Data Output	3	
25	CML-O	Rx4p	Receiver Non-Inverted Data Output	3	
26		GND	Ground	1	1
27	LVTTTL-O	ModPrsL	Module Present	3	
28	LVTTTL-O	IntL	Interrupt	3	
29		Vcc Tx	+3.3V Power supply transmitter	2	2
30		Vcc1	+3.3V Power supply	2	2
31	LVTTTL-I	LPMODE	Low Power Mode	3	
32		GND	Ground	1	1
33	CML-I	Tx3p	Transmitter Non-Inverted Data Input	3	
34	CML-I	Tx3n	Transmitter Inverted Data Input	3	
35		GND	Ground	1	1
36	CML-I	Tx1p	Transmitter Non-Inverted Data Input	3	
37	CML-I	Tx1n	Transmitter Inverted Data Input	3	
38		GND	Ground	1	1

**Note :**

1. **GND** is the symbol for signal and supply (power) common for the QSFP module. All are common within the QSFP+ module and all module voltages are referenced to this potential unless otherwise noted. Connect these directly to the host board signal-common ground plane.
2. **Vcc Rx, Vcc1 and Vcc Tx** are the receiver and transmitter power supplies and shall be applied concurrently. Requirements defined for the host side of the Host Edge Card Connector are listed in Table. Recommended host board power supply filtering is shown in Host board power supply circuit. Vcc Rx Vcc1 and Vcc Tx may be internally connected within the QSFP+ module in any combination. The connector pins are each rated for a maximum current of 500 mA.

■ Memory Map

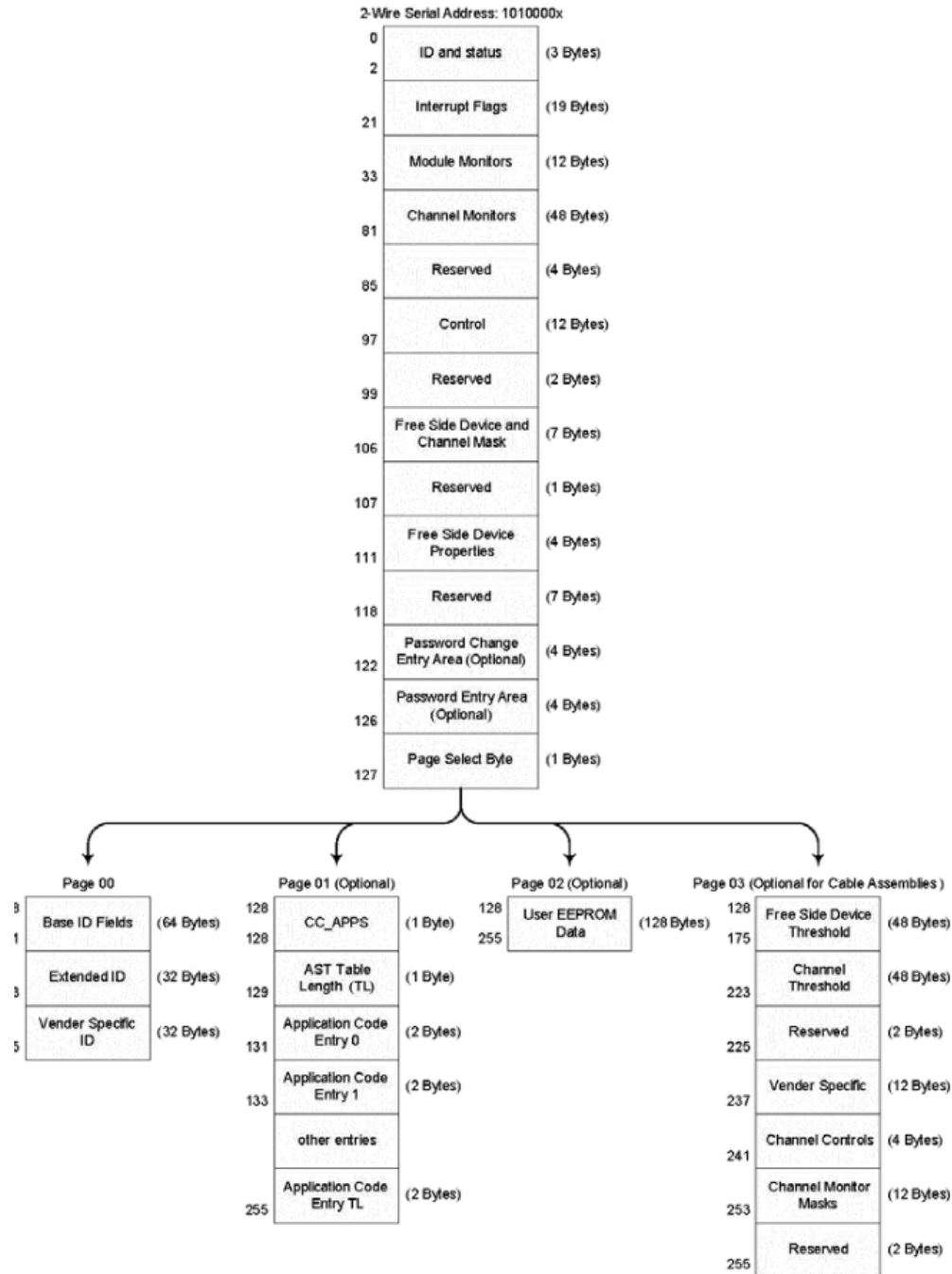

## ■ Module Outline

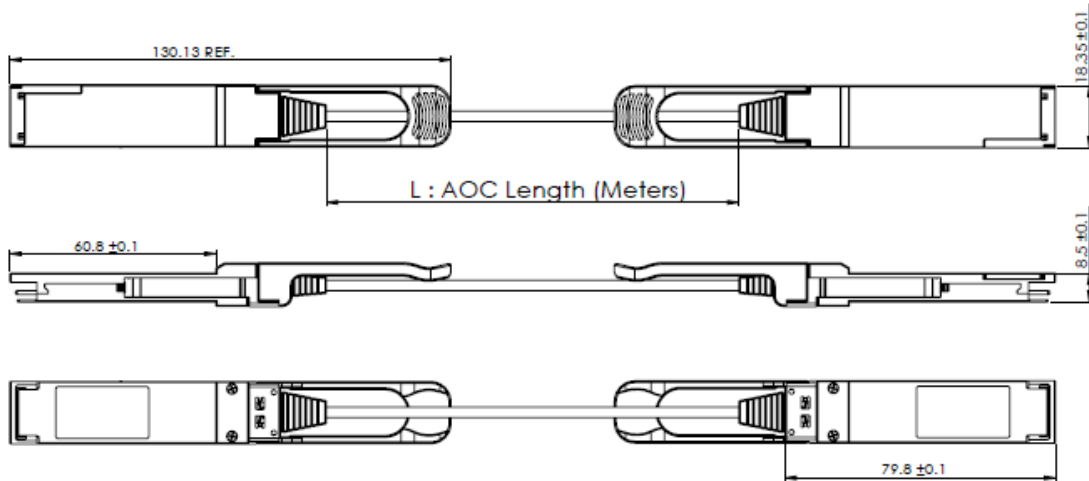

## ■ ESD

Normal ESD precautions are required during the handling of this module. This transceiver is shipped in ESD protective packaging. It should be removed from the packaging and handled only in an ESD protected environment.

## ■ LASER Safety

This is a Class 1 Laser Product according to IEC/EN60825-1:2014 (Third Edition). This product complies with 21 CFR 1040.10 and 1040.11 except for deviations pursuant to Laser Notice No. 56, MAY 8, 2019.

### Caution:

Use of controls or adjustments or performance of procedures other than those specified herein may result in hazardous radiation exposure.

Attention: L'utilisation de commandes ou de réglages ou l'exécution de procédures autres que celles spécifiées dans le document peut entraîner une exposition à des radiations dangereuses.



■ **Contact Information**

**Formerica OptoElectronics Inc.**

5F-11, No.38, Taiyuan St., Zhubei City,  
Hsinchu County 30265, Taiwan

Tel: +886-3-5600286

Fax: +886-3-5600239

**San Diego, CA**

Tel: 1-949-466-8069

[inquiry@formericaoe.com](mailto:inquiry@formericaoe.com)

[www.formericaoe.com](http://www.formericaoe.com)

## ■ Revision History

Date	Version	Description
05/07/2021	Preliminary	
05/13/2021	0.1	Update product picture
5/24/2021	1.0	Update mechanical drawing