

Specification**Quad Small Form-factor Pluggable****Optical Transceiver Module****40GBASE-SR4****Ordering Information****TQS-Q1LH9-2CA**

Model Name	Voltage	Category	Device type	Interface	Temperature	Distance
TQS-Q1LH9-2CA	3.3V	With DDMI	850 nm VCSEL	CML/CML	0°C ~+70°C	100m /150m (OM3/OM4)

Description

FormericaOE Inc. Quad Small Form-factor Pluggable Plus (QSFP+) product is a new high speed pluggable I/O interface products. This interconnecting system offers 4 channels and maximum bandwidth of 40Gbps which are based on the proprietary technique Silicon Optical Bench (SiOB) as an optical engine. This module provides high performance and excellent efficiency in the short-reach (SR) optical interconnects.

Features

- Compliant with 40G Ethernet IEEE 802.3ae 40GBASE-SR4 standards
- Compliant to SFF-8436 QSFP+ Specification Revision 4.0
- Supports 40 Gbps data rate links of up to 150 m
- Low power consumption of max 1.5 W Power Level 1 compliance
- Hot pluggable electrical interface
- Using standard 12/8 lane optical fiber with MPO pluggable optical connector.
- 0 to 70°C case temperature operating range
- RoHS Compliant

Applications

- 40GBASE-SR4 Ethernet links
- InfiniBand QDR and DDR interconnects
- 4G / 8G / 10G Fiber Channel
- SATA/SAS Storage
- HPC Interconnects
- Client-side 40G Telecom connections

Absolute Maximum Rating

Not necessarily applied together. Exceeding these values may cause permanent damage. Functional operation under these conditions is not implied.

Parameter	Symbol	Min	Typical	Max	Unit	Note
Storage Temperature	T _s	-40		100	°C	
3.3V Power Supply Voltage	V _{cc}	-0.5		3.6	V	
Data Input Voltage-Single Ended		-0.5		V _{cc} +0.5	V	
Data Input Voltage-Single Ended	V _{DIP-} V _{DIN}			1.0	V	
Relative Humidity	RH	5		85	%	

Recommended Operating Conditions

Parameter	Symbol	Min	Typical	Max	Unit	Note
Case Temperature	T _{op}	0	40	70	°C	
3.3 V Power Supply Voltage	V _{cc}	3.135	3.3	3.465	V	
Signal Rate per Channel		2.5		10.3125	Gbps	
Control* Input Voltage High	V _{ih}	2		V _{cc} +3	V	
Control* Input Voltage Low	V _{il}	-0.3		0.8	V	
Two Wire Serial (TWS) Interface Clock Rate				400	kHz	
Receiver Differential Data Output Load			100		Ohms	
Fiber Length: 2000 MHz·km 50µm MMF (OM3)		0.5		100	m	
Fiber Length: 4700 MHz·km 50µm MMF (OM4)		0.5		150	m	

Transceiver Electrical Characteristics

The following characteristics are defined over the Recommended Operating Conditions unless otherwise noted. Typical values are for $T_{op} = 40^{\circ}\text{C}$, $V_{cc} = 3.3\text{ V}$.

Parameter	Symbol	Min	Typical	Max	Unit	Note
TRx Power Consumption				1.5	W	
TRx Power Supply Current				420	mA	
TRx Power-On Initialization Time	tpwr init			2000	ms	1.

Notes:

1. "Initialization Time" is the time from when the supply voltages reach and remain above the minimum "Recommended Operating Conditions" to the time when the module enables TWS access. The module at that point is fully functional.

Electrical Characteristics

Parameter	Symbol	Min	Typical	Max	Unit	Note
Transmitter Electrical Characteristics						
Data Input Differential Peak-to-Peak Voltage Swing	ΔVDI_{PP}	175		1600	mVpp	
LOS Assert Threshold: Tx Data Input Differential Peak-to-Peak Voltage Swing	$\Delta\text{VDI}_{PP\text{ LOS}}$	50			mVpp	
Differential input threshold			50		mV	
Receiver Electrical Characteristics						
Data Output Differential Peak-to-Peak Voltage Swing (AC-Coupled)	ΔVDO_{pp}	200		900	mVpp	
Output transition time 20% to 80%	Tr / Tf	28			ps	
Output Total Jitter				62	ps	

Optical Characteristics

Parameter	Symbol	Min	Typical	Max	Unit	Note
Transmitter Optical Characteristics						
Center Wavelength	λ	840		860	nm	
Spectral Width – RMS	$\sigma\lambda$			0.65	nm	
Output Optical Power: Average	PO AVE	-7.6		2.4	dBm	
Output Optical Modulation Amplitude, per lane		-5.6		3	dBm	
Extinction Ratio	ER	3			dB	
Output Optical Power: Disabled	PO OFF			-30	dBm	
Eye Mask				Compliant with IEEE 802.3ba D3.2		
Receiver Optical Characteristics						
Center wavelength, each lane	λ	840	850	860	nm	
Damage Threshold		3.4			dBm	
Maximum Average power at receiver input, each lane				2.4	dBm	
Receiver Reflectance				-12	dB	
Stressed receiver sensitivity (Avg)				-5.4	dBm	1
LOS Assert		-30			dB	
LOS De-Assert				-7.5	dB	
LOS Hysteresis		0.5			dB	

Notes:

1. Measured with 10.3125-Gbps of PRBS-31 at 10^{-12} BER.

QSFP+ Module Pad Assignments and Descriptions

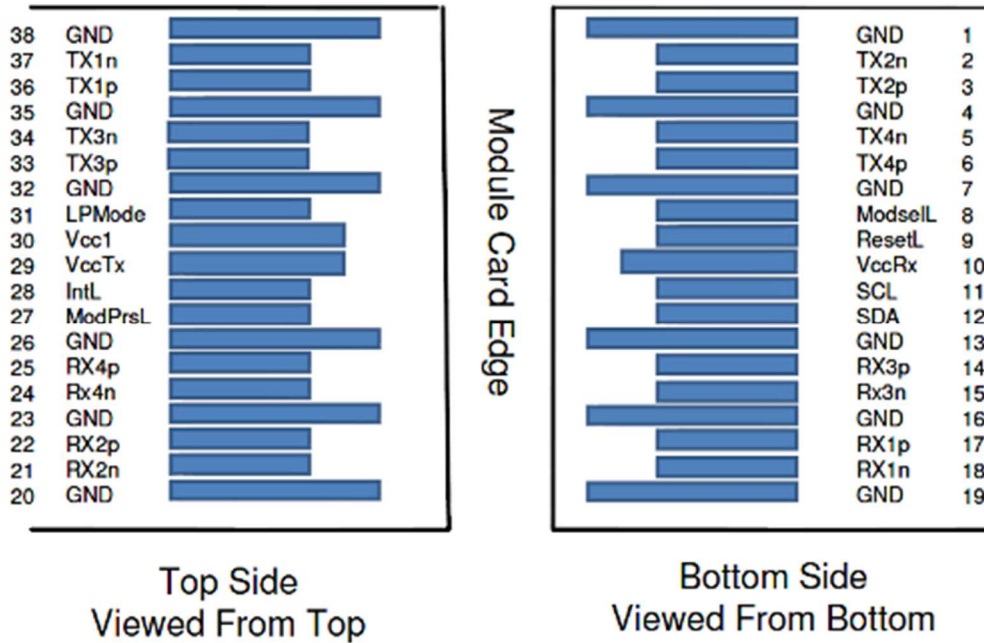

Pin	Logic	Symbol	Description	Plug Sequence	Notes
1		GND	Ground	1	1
2	CML-I	Tx2n	Transmitter Inverted Data Input	3	
3	CML-I	Tx2p	Transmitter Non-Inverted Data Input	3	
4		GND	Ground	1	1
5	CML-I	Tx4n	Transmitter Inverted Data Input	3	
6	CML-I	Tx4p	Transmitter Non-Inverted Data Input	3	
7		GND	Ground	1	1
8	LVTTTL-I	ModSelL	Module Select	3	
9	LVTTTL-I	ResetL	Module Reset	3	
10		Vcc Rx	+3.3V Power Supply Receiver	2	2
11	LVCMOS-I/O	SCL	2-wire serial interface clock	3	
12	LVCMOS-I/O	SDA	2-wire serial interface data	3	
13		GND	Ground	1	2
14	CML-O	Rx3p	Receiver Non-Inverted Data Output	3	
15	CML-O	Rx3n	Receiver Inverted Data Output	3	
16		GND	Ground	1	1

17	CML-O	Rx1p	Receiver Non-Inverted Data Output	3	
18	CML-O	Rx1n	Receiver Inverted Data Output	3	
19		GND	Ground	1	1
20		GND	Ground	1	1
21	CML-O	Rx2n	Receiver Inverted Data Output	3	
22	CML-O	Rx2p	Receiver Non-Inverted Data Output	3	
23		GND	Ground	1	1
24	CML-O	Rx4n	Receiver Inverted Data Output	3	
25	CML-O	Rx4p	Receiver Non-Inverted Data Output	3	
26		GND	Ground	1	1
27	LVTTTL-O	ModPrs L	Module Present	3	
28	LVTTTL-O	IntL	Interrupt	3	
29		Vcc Tx	+3.3V Power supply transmitter	2	2
30		Vcc1	+3.3V Power supply	2	2
31	LVTTTL-I	LPMMode	Low Power Mode	3	
32		GND	Ground	1	1
33	CML-I	Tx3p	Transmitter Non-Inverted Data Input	3	
34	CML-I	Tx3n	Transmitter Inverted Data Input	3	
35		GND	Ground	1	1
36	CML-I	Tx1p	Transmitter Non-Inverted Data Input	3	
37	CML-I	Tx1n	Transmitter Inverted Data Input	3	
38		GND	Ground	1	1

Note 1: GND is the symbol for signal and supply (power) common for the QSFP+ module. All are common within the QSFP+ module and all module voltages are referenced to this potential unless otherwise noted. Connect these directly to the host board signal-common ground plane.

Note 2: Vcc Rx, Vcc1 and Vcc Tx are the receiver and transmitter power supplies and shall be applied concurrently. Requirements defined for the host side of the Host Edge Card Connector are listed in Table . Recommended host board power supply filtering is shown in Figure . Vcc Rx Vcc1 and Vcc Tx may be internally connected within the QSFP+ module in any combination. The connector pins are each rated for a maximum current of 500 mA.

Recommended Host Board Power Supply Circuit

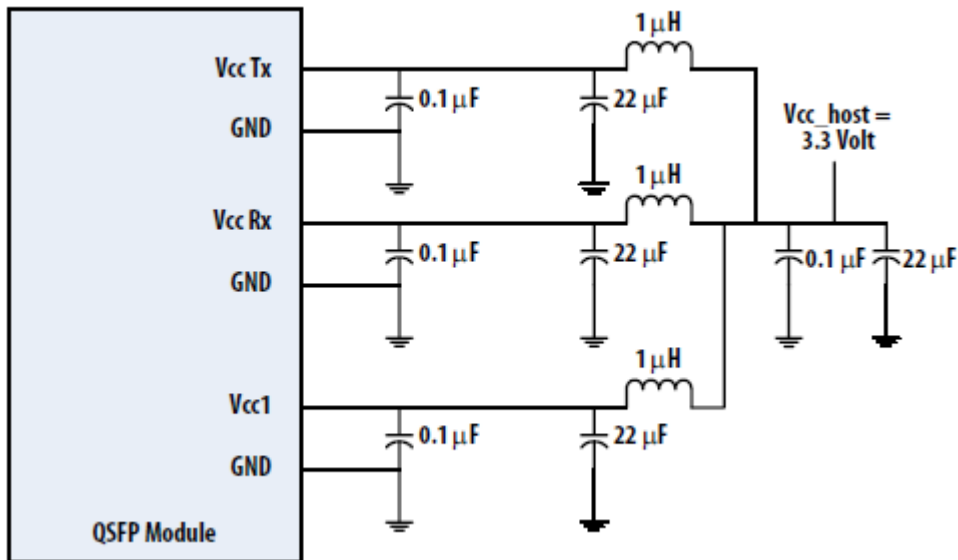

Recommended Interface Circuit

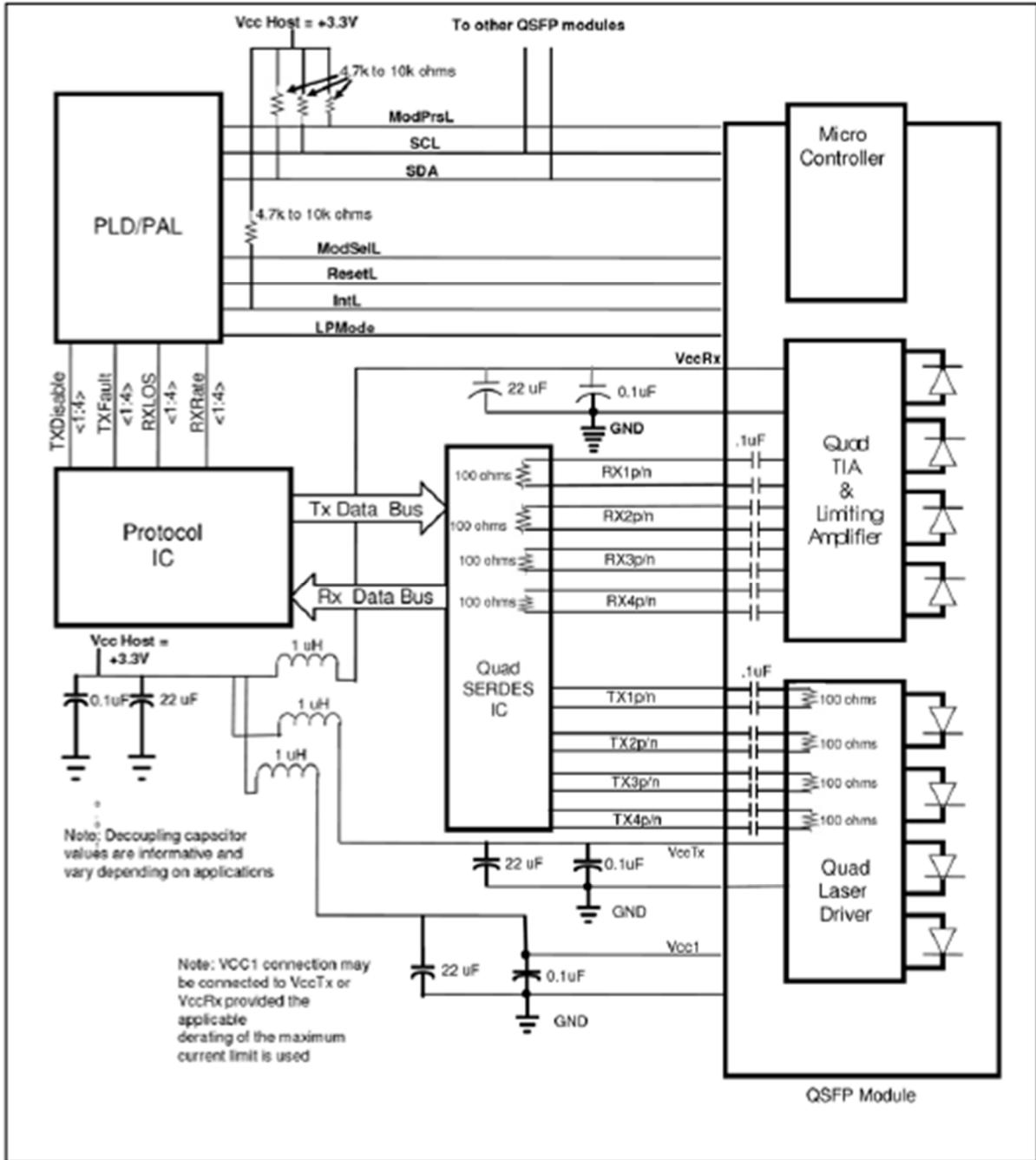

Memory Map

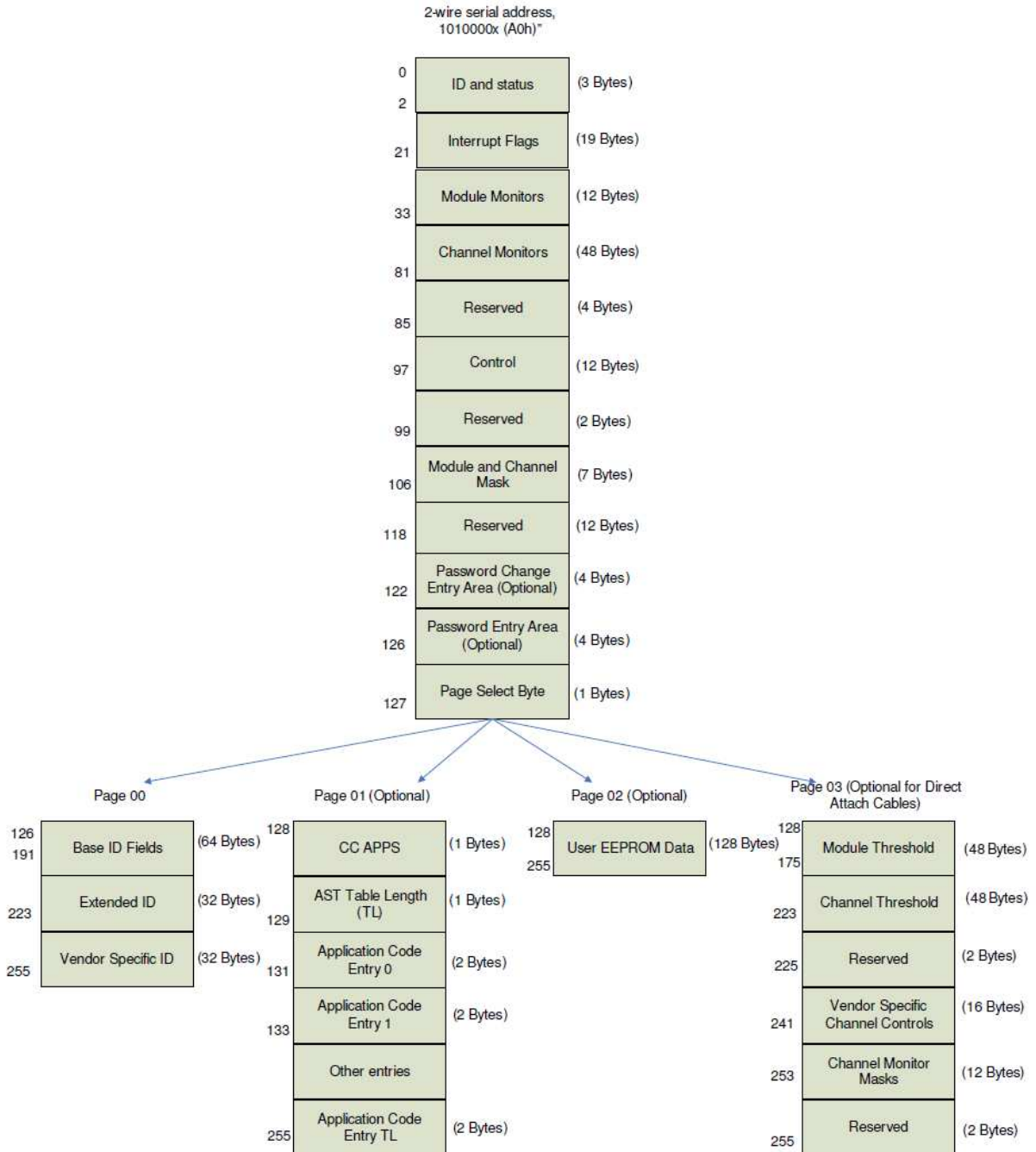

Mechanical Design Diagram

Unit: mm

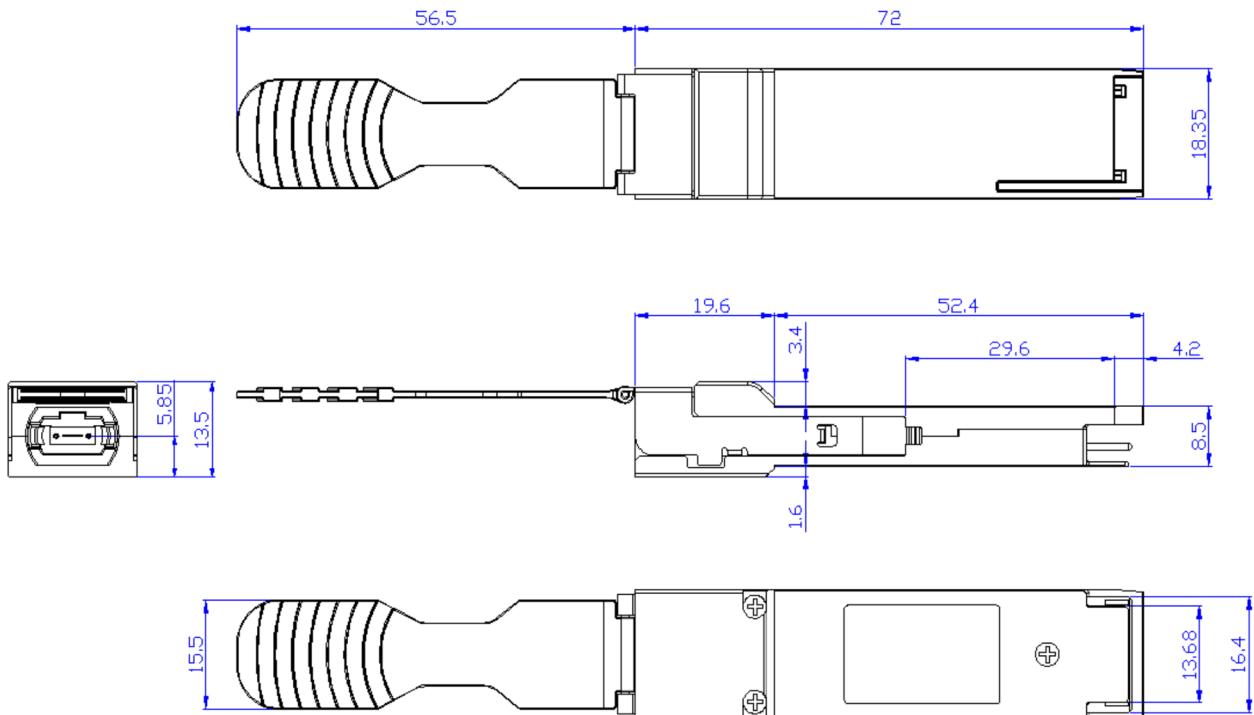

ESD

Normal ESD precautions are required during the handling of this module. This transceiver is shipped in ESD protective packaging. It should be removed from the packaging and handled only in an ESD protected environment.

Laser Safety

This is a laser class 1M product according to IEC / EN 60825-1: 2014 (Third Edition). This product complies with 21 CFR 1040.10 and 1040.11 except for deviations pursuant to Laser Notice No. 50, dated June 24, 2007.



Contact Information

Formerica OptoElectronics Inc.

5F-11, No.38, Taiyuan St., Zhubei City,
Hsinchu County 30265, Taiwan

Tel: +886-3-5600286

Fax: +886-3-5600239

San Diego, CA

Tel: 1-949-466-8069

inquiry@formericaoe.com

www.formericaoe.com